

ROME - ITALY  
"RIONE MONTI" DOWNTOWN



**MyTALE**  
CREATIVE ACADEMY HOTEL  
ROME



## D O W N T O W N

MyTALE rises in a early '900 building located behind the Forum of Augustus, in Rione Monti, or Rione I, the oldest in Rome, eclectic and crossed by mutations and contamination, so much to live a life of its own, Suburra (so it was called in Roman era from "Sub Urbe" - under the city - whose basements came out at the Colosseum). It is here that MyTALE has drawn his essence, the need to tell some of the many faces of a Rome that never ceases to surprise.



MAP OF HISTORIC  
CENTER OF ROME



CASTEL  
SANT'ANGELO

PIAZZA DI SPAGNA

PIAZZA NAVONA

FONTANA DI TREVI

PANTHEON

STAZIONE  
TERMINI

  
**MOTALE**  
CREATIVE ACADEMY HOTEL  
ROME

SANTA MARIA  
MAGGIORE

PIAZZA VENEZIA

CAMPIDOGLIO

FORO ROMANO

COLOSSEO

D E S I G N

MyTALE, 5 star hotel,  
precious details and home  
of a *creative academy*,  
the hotel is born from an  
artistic process that opens  
to a constantly evolving flow.

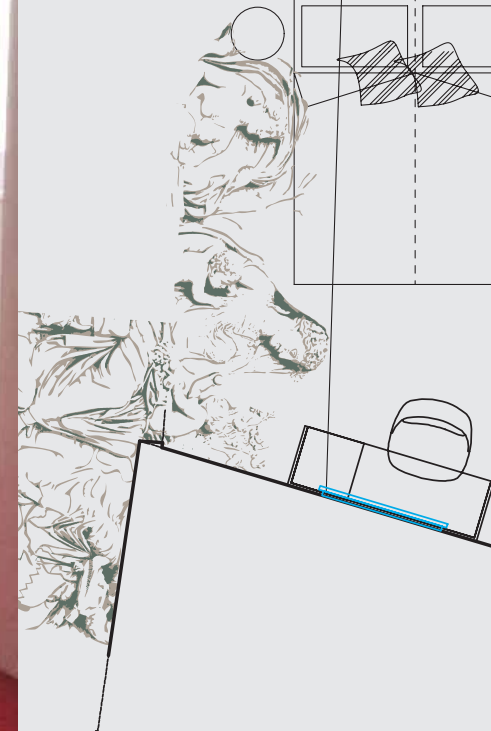
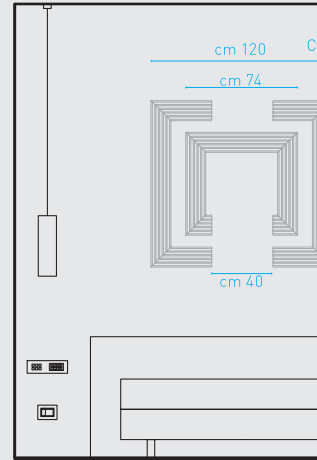

DESIGN

MyTALE combines the innovation of a high-level *guest experience* with the temporal *tale* of Imperial Rome, passing through the Renaissance to the Contemporary.

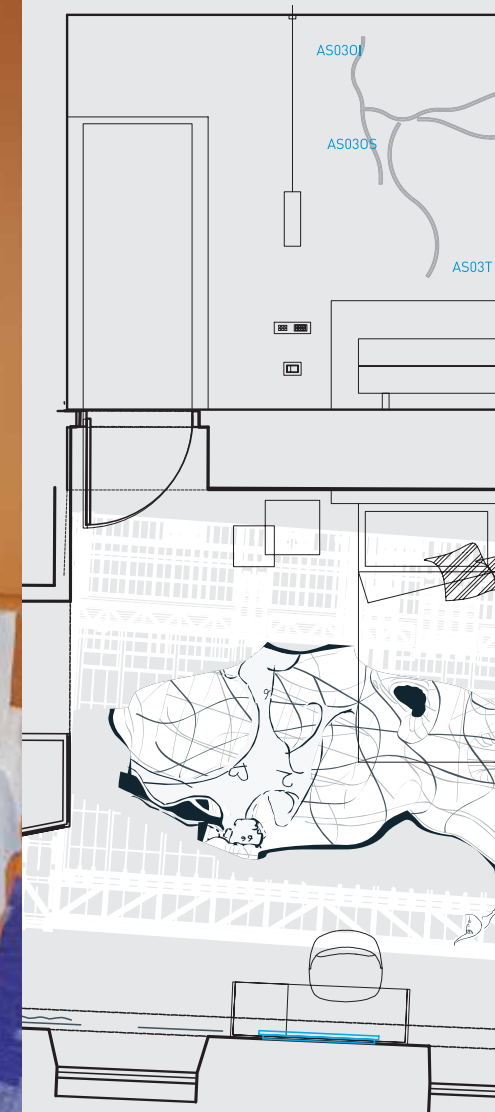

## ART CONCEPT



A tale of monuments, architectural works, decorations, frescoes, mosaics and paintings is revealed under our feet, printed on *art moquettes*, the drawings by the artist Patrizia Marrocco, exclusive to MyTALE, are the leitmotif of the art concept: It is a route through the three floors and, with the addition of a refined color palette, translates the stay into an emotional experience: atmospheres captured, interpreted, regenerated on the timeline.





ART CONCEPT

Every design on moquette evokes the breath, the greatness, the aspiration of great artists and architects of every time and place, their desire to overcome and amaze, contributing with their works to make of Rome “*a great museum, a living room to cross on tiptoe*” (Alberto Sordi).

## RENOVATION

In MyTALE creative academy  
HOTEL cohabits:  
hi-tech innovation, care and  
historic-artistic enhancement  
building, furnishing accessories  
exclusively projected between  
art and design, relax and  
comfort for physical and psychic  
wellness.



Project by  
CAP creative design





All MyTALE creative academy HOTEL rooms offer a high level *guest experience* and a concept of hospitality that translates into a *form of art and thought*.

Designed with the highest expression of Italian interior designers, they follow a conceptual artistic path, the rooms are welcoming and bright, with bold tones.

The comfortable bathrooms, with floors and coatings with changing effects of marble are equipped with a spacious shower double, some with an area exclusive wellness, soft bathrobes in chenille and luxurious amenities signed "Ortigia" with a particular attention to the environment.

Each room has an art moquette designed exclusively. Every art creation is born from a project that is a path in dialogue with the art that has inhabited and that still animates Rome, from the imperial to the contemporary.

This makes MyTALE *a place where form and aesthetics open to an inner flow reinterpreting art and, together, the artists who made this city great.*

## R O O M S



15 rooms

4 categories:

3

A B S O L U T E  
Gran Suite

3

I N S P I R A T I O N  
Wellness Deluxe

3

C R E A T I O N  
Gallery Suite

3

V I E W  
Suite

3

S O U L  
Deluxe





ABSOLUTE  
Gran Suite



A B S O L U T E  
Gran Suite

AREA 52 M<sup>2</sup>, 560 SQFT

SIDE STREET VIEW: VIA CLEMENTINA AND  
INTERNAL COURTYARD

WELLNESS AREA (HAMMAM, EMOTIONAL  
SHOWER OR WATERFALL SHOWER)

FREE INTERNET WI-FI

MINI BAR AND NESPRESSO COFFEE MACHINE  
WITH PODS

KETTLE WITH SELECTION OF TEA AND  
INFUSIONS

55 INCH TV WITH LED SCREEN

SATELLITE CHANNELS

LAPTOP SAFE 15"

AIR CONDITIONING/CENTRAL HEATING

TELEPHONE

HAIR DRYER (HAIR STRAIGHTENER ON  
REQUEST)

CHENILLE BATHROBE AND SLIPPERS

MANET MOBILE DEVICE

LINE AMENITY ORTIGIA ALLUMINIUM

HIS & HERS BEAUTY KIT

WEBAPP CONCIERGE

SCALE

24 HOUR ROOM SERVICE

SEPARATED LIVING AREA

2 BEDROOMS

MAX CAPACITY : 5 ADULTS + 1 INFANT (0-3  
YEARS)

PILLOW MENU

MOBILE CHARGER WIRELESS

DESK



INSPIRATION  
Wellness Deluxe



INSPIRATION  
Wellness Deluxe

AREA 23 M<sup>2</sup>, 250 SQFT

SIDE STREET VIEW: VIA CLEMENTINA

WELLNESS AREA (HAMMAM, EMOTIONAL  
SHOWER OR WATERFALL SHOWER)

FREE INTERNET WI-FI

MINI BAR AND NESPRESSO COFFEE MACHINE  
WITH PODS

KETTLE WITH SELECTION OF TEA AND  
INFUSIONS

55 INCH TV WITH LED SCREEN

SATELLITE CHANNELS

LAPTOP SAFE 15"

AIR CONDITIONING/CENTRAL HEATING

TELEPHONE

HAIR DRYER (HAIR STRAIGHTENER ON  
REQUEST)

CHENILLE BATHROBE AND SLIPPERS

MANET MOBILE DEVICE

LINE AMENITY ORTIGIA ALLUMINIUM

HIS & HERS BEAUTY KIT

WEBAPP CONCIERGE

SCALE

24 HOUR ROOM SERVICE

MAX CAPACITY : 2 ADULTS + 1 INFANT (0-3  
YEARS)

PILLOW MENU

MOBILE CHARGER WIRELESS

DESK



CREATION  
Gallery Suite



CREATION  
Gallery Suite

- AREA 28 M<sup>2</sup>, 300 SQFT
- VIEW OF THE ARTISTIC INNER COURT
- FREE INTERNET WI-FI
- MINI BAR AND NESPRESSO COFFEE MACHINE WITH PODS
- KETTLE WITH SELECTION OF TEA AND INFUSIONS
- 55 INCH TV WITH LED SCREEN
- SATELLITE CHANNELS
- LAPTOP SAFE 15"
- AIR CONDITIONING/CENTRAL HEATING
- TELEPHONE
- HAIR DRYER (HAIR STRAIGHTENER ON REQUEST)
- CHENILLE BATHROBE AND SLIPPERS
- MANET MOBILE DEVICE
- LINE AMENITY ORTIGIA ALLUMINIUM
- HIS & HERS BEAUTY KIT
- WEBAPP CONCIERGE
- SCALE
- 24 HOUR ROOM SERVICE
- SEPARATE LIVING AREA
- MAX CAPACITY: 3 ADULTS + 1 INFANT (0-3 YEARS)
- PILLOW MENU
- MOBILE CHARGER WIRELESS
- DESK



VIEW  
Suite







VIEW  
Suite

AREA 31 M<sup>2</sup>, 333 SQFT

FRONT VIEW: PIAZZA DEGLI ZINGARI

FREE INTERNET WI-FI

MINI BAR AND NESPRESSO COFFEE MACHINE  
WITH PODS

KETTLE WITH SELECTION OF TEA AND  
INFUSIONS

55 INCH TV WITH LED SCREEN

SATELLITE CHANNELS

LAPTOP SAFE 15"

AIR CONDITIONING/CENTRAL HEATING

TELEPHONE

HAIR DRYER (HAIR STRAIGHTENER ON  
REQUEST)

CHENILLE BATHROBE AND SLIPPERS

MANET MOBILE DEVICE

LINE AMENITY ORTIGIA ALLUMINIUM

HIS & HERS BEAUTY KIT

WEBAPP CONCIERGE

SCALE

24 HOUR ROOM SERVICE

MAX CAPACITY: 3 ADULTS + 1 INFANT (0-3  
YEARS)

PILLOW MENU

MOBILE CHARGER WIRELESS

DESK



SOUL  
Deluxe





S O U L  
Deluxe

- AREA 19 M<sup>2</sup>, 204 SQFT
- SIDE STREET VIEW: VIA CLEMENTINA
- FREE INTERNET WI-FI
- MINI BAR AND NESPRESSO COFFEE MACHINE WITH PODS
- KETTLE WITH SELECTION OF TEA AND INFUSIONS
- 55 INCH TV WITH LED SCREEN
- SATELLITE CHANNELS
- LAPTOP SAFE 15"
- AIR CONDITIONING/CENTRAL HEATING
- TELEPHONE
- HAIR DRYER (HAIR STRAIGHTENER ON REQUEST)
- CHENILLE BATHROBE AND SLIPPERS
- MANET MOBILE DEVICE
- LINE AMENITY ORTIGIA ALLUMINIUM
- HIS & HERS BEAUTY KIT
- WEBAPP CONCIERGE
- SCALE
- 24 HOUR ROOM SERVICE
- MAX CAPACITY : 2 ADULTS + 1 INFANT (0-3 YEARS)
- PILLOW MENU
- MOBILE CHARGER WIRELESS
- DESK

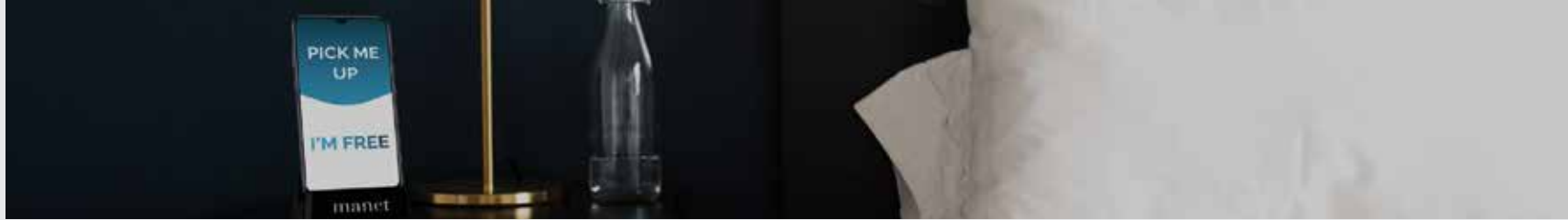

## T R A V E L   E X P E R I E N C E S

In each room of our hotel *you will find a Manet device*, made available for free for the entire duration of your stay.

The Manet device is a digital travel assistant that offers free and unlimited national and international calls, free Internet connection even outside the hotel, without the need for Wi-Fi access points.

Direct booking of hotel services is available on the Manet device even when you are out and about the city.

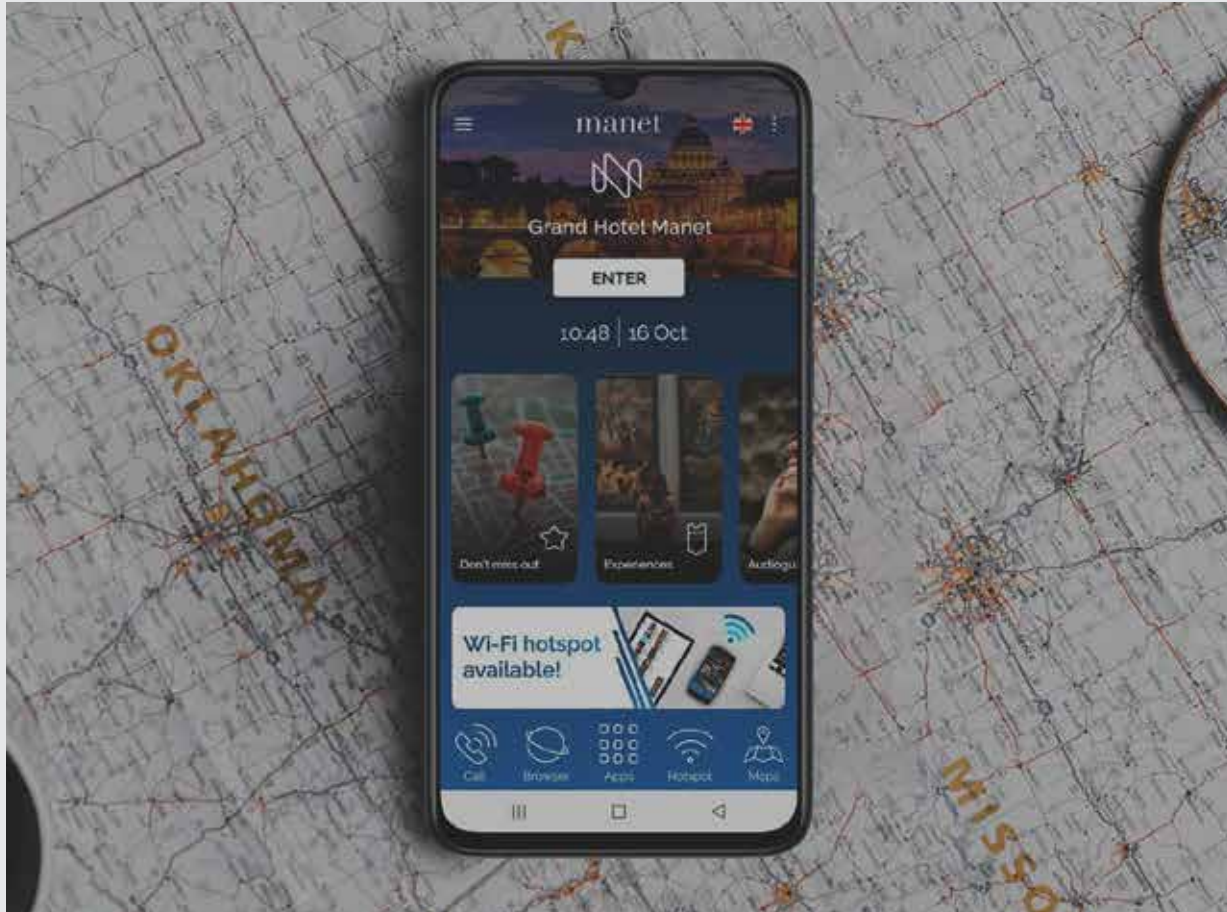

## F R E E   M A N E T   D E V I C E

Manet allows you to enjoy your destination thanks to tourist guides, food and wine and travel advice.

From the Manet device, you can directly access premium features such as hotspots (you can share the connection with your personal devices!) and multilingual audio guides to the most important points of interest. You can also buy tickets for attractions, museums and experiences.



RECEPTION



MyTALE

CREATIVE ACADEMY HOTEL  
ROME

The Reception Hall of MyTALE gets inspiration from the scenography works of Enrico Prampolini (1894-1956), painter, sculptor, set designer and costume designer.

“Geometry presides over our creations, such as syntax in the literature the counterpoint for music, which latent language of the composition”  
(Enrico Prampolini)





## BISTROT

Inspired environments and symbols to the futurist image-icon of the silent film *Thaïs*, an atmosphere that retraces the narration and a taste of the amazing imaginary.

Mediterranean and essential, our cuisine is

- search between tradition and innovation
- attention to the seasonal and quality of products
- union between taste, history, beauty and wellness



## R O O F

The terrace, RI.one Roof of MyTALE is a top view of Rione Monti, on Rome... on the world.

After meeting the past and the present, going up to the fourth floor of MyTALE, we reach the inscrutable future.

*The future is hidden from our eyes but change in us before it is revealed.*



Culture, art, music, cinema, video art, theatre, dance, architecture, photography, philosophy, psychology, literature, poetry, neuroscience, personal growth, the CREATIVE ACADEMY aspires to:

argue and practice the "knowable", lead knowledge to be comprehensible experience;

promote the excellence and maximising the value of the potential of the individual, but always in an egalitarian perspective, which opens to "integration" and "interrelation" as well as "understanding of complexity";

encourage to the exchange of synergies between the individual and the community, an evolutionary spiral that converges to a process of growth in which each part contributes to a unique and fundamental role, like every single musical instrument in an orchestra;;

be the place, the crossroads, to exercise body and mind, the agorà where to practice beauty. EVENTS, MEETINGS, EXHIBITIONS.

E V E N T S  
M E E T I N G S  
E X H I B I T I O N S



CREATIVE  
ACADEMY

INDIVIDUAL META-ELEVATION  
STUDIES AND RESEARCH







MyTALE

CREATIVE ACADEMY HOTEL  
ROME

"RIONE MONTI" DOWNTOWN



VISIT US



[www.mytalerome.com](http://www.mytalerome.com)



[hello@mytalerome.com](mailto:hello@mytalerome.com)

